

DISCS

BLACK DISC

WHITE DISC

140051UHMW

140051UHMWW



FUNCTION

CABLE DISCS are tapered to give strength to the disc cross-section and to provide a cavity for capturing the cable slug. The front face of the disc is slightly cupped to give lift to the product and thus less pull on the cable as the product is being conveyed.

Cable Discs are replaceable. If one disc should be damaged, it can be replaced. If all conveyor discs are badly worn, they may be replaced without replacing the cable.

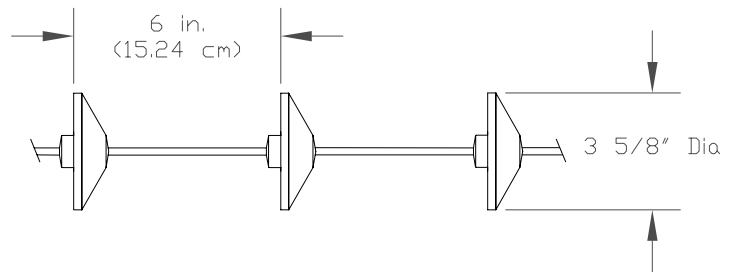

INSTALLATION

Place two plastic disc halves over a cable slug and fasten with two screws. Since the disc spacing is 6 in. (15.24 cm), four (4) disc halves and four (4) fasteners are required per foot of conveyor cable.

PART ASSEMBLY

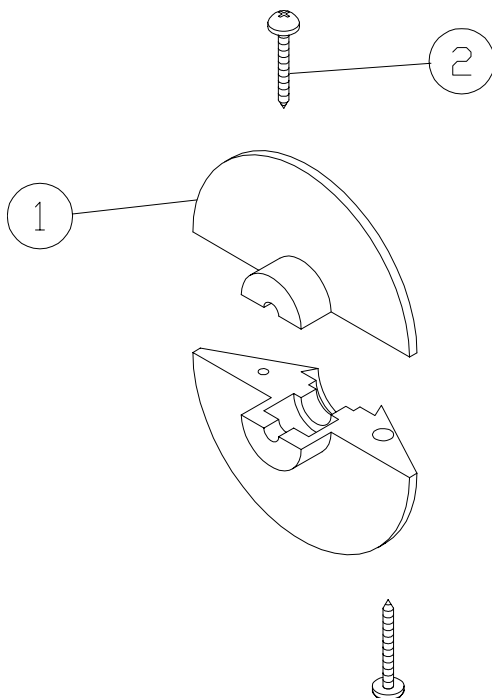

PART NUMBER IDENTIFICATION

C00143UHMW Black Disc with SS Fastener			
ITEM	PART NO.	DESCRIPTION	QTY.
1	140051UHMW	4" DISC HALF BLACK	2
2	01984	#10 x 1 1/4 SS TAPPING SCREW	2

C00143UHMWW White Disc with SS Fastener			
ITEM	PART NO.	DESCRIPTION	QTY.
1	140051UHMWW	4" DISC HALF WHITE	2
2	01984	#10 x 1 1/4 SS TAPPING SCREW	2

C00143UHMWWP White Disc with Plastic Fastener			
ITEM	PART NO.	DESCRIPTION	QTY.
1	140051UHMWW	4" DISC HALF WHITE	2
2	02016	10-32 x 1 1/4 NYLON HEX SOCKET SCREW	2

CABLE CONNECTOR

STAINLESS STEEL C00160SS



FUNCTION

The **CABLE CONNECTOR** attaches the two ends of the cable together to complete the loop. The two-piece metal connector is joined together with an internal snap ring, which allows any rotational twist in the cable to be self-correcting.

After each connector half is attached to the ends of the cable with set screws and the snap ring is installed, connector disc halves are placed over the connector assembly and secured with fasteners. The snap ring may be removed from the connector assembly and the cable ends separated without taking off the connector disc halves.



INSTALLATION

1. After the cable with discs is pulled into the system, double check that the drive unit teeth push against the cable slugs and not against the plastic discs. Also check the direction of cable travel. The cupped side of the disc pushes the product to be conveyed.

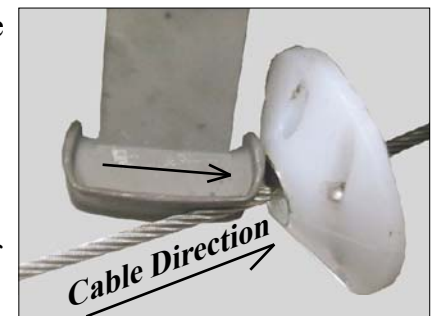

Now that the cable travel direction has been confirmed, the cable connector gauge may be used to determine the exact cuts for each end of the cable and the placement of each cable connector half.



2. To join the cable ends, one of the slugs must be removed from one end of the cable. With the cable travel direction from right to left, use a torch to melt the end slug off the right end of the cable. Rotate the cable slowly while applying heat just long enough for the zinc or plastic to start melting. **DO NOT HEAT THE ZINC SLUG ANY LONGER THAN NECESSARY** – use pliers to scrape the molten zinc slug off the cable.



3. Now place the right end of the cable in the gauge and cut the cable at the notch ***in the middle of the connector gauge.***

CABLE CONNECTOR

STAINLESS STEEL C00160SS



INSTALLATION (Cont.)

4. Slide the female connector over end of cable. Use the gauge to hold the connector in position and tighten the set screws to 140 in.- lb. with the long hex wrench provided (Item 2, Cable Connector Kit). (A 24 lb. pull on the end of the 6 in. long Allen wrench gives the required 140 in. – lb. torque.) The cable end should be flush with the inside of the connector.

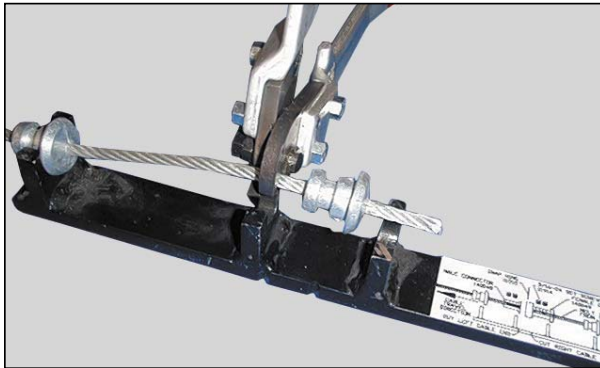
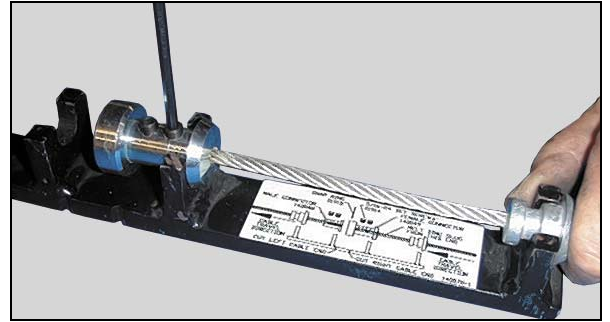

5. Place the left end of the cable in the gauge and cut the cable at the notch *in the “side” notch – not the center notch – in the connector gauge.*



6. Slide the male connector half onto the cable, use the gauge to hold the connector half in position and tighten the set screws to 140 in. – lb. (A 24 lb. pull on the end of the 6 in. long Allen wrench gives the required 140 in.– lb. torque.) The cable end should be flush with the end of the male connector.



7. Join the two ends together and insert the snap ring into the groove with the sharp edge of the snap ring facing out. Rotate the snap ring within the connector groove to insure proper seating of the ring in the groove.



8. Install the disc halves over the zinc slugs on both sides of the connector.



9. Install the connector disc halves over the cable connector.



INSTALLATION (Cont.)

10. The distance between the discs on the cable is 6 in. (15.24 cm). Therefore, the cable connector disc should also measure 6 in. (15.24 cm) from the discs on either side of it.

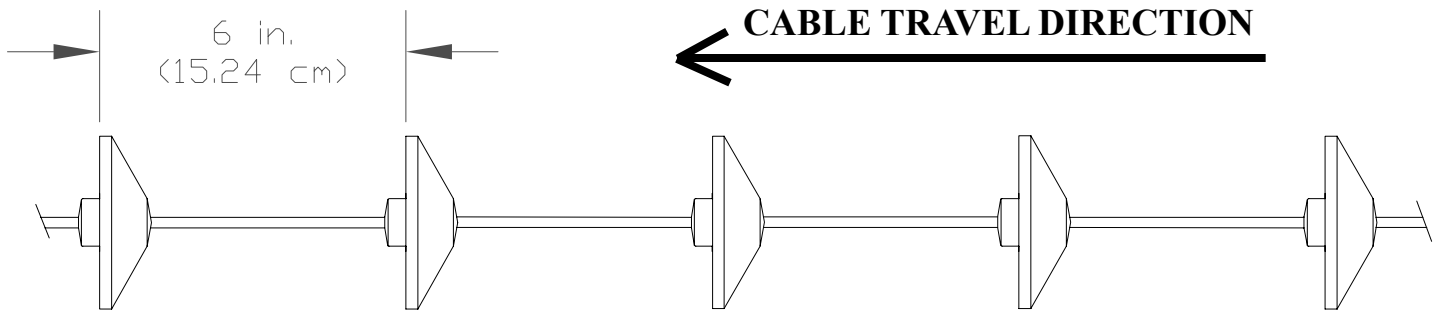

11. After the system has been run about 25 hours, remove the connector disc and retighten the four connector set screws to 140 in. – lb. torque. Reinstall the connector disc halves.

INSTALLATION DIAGRAM

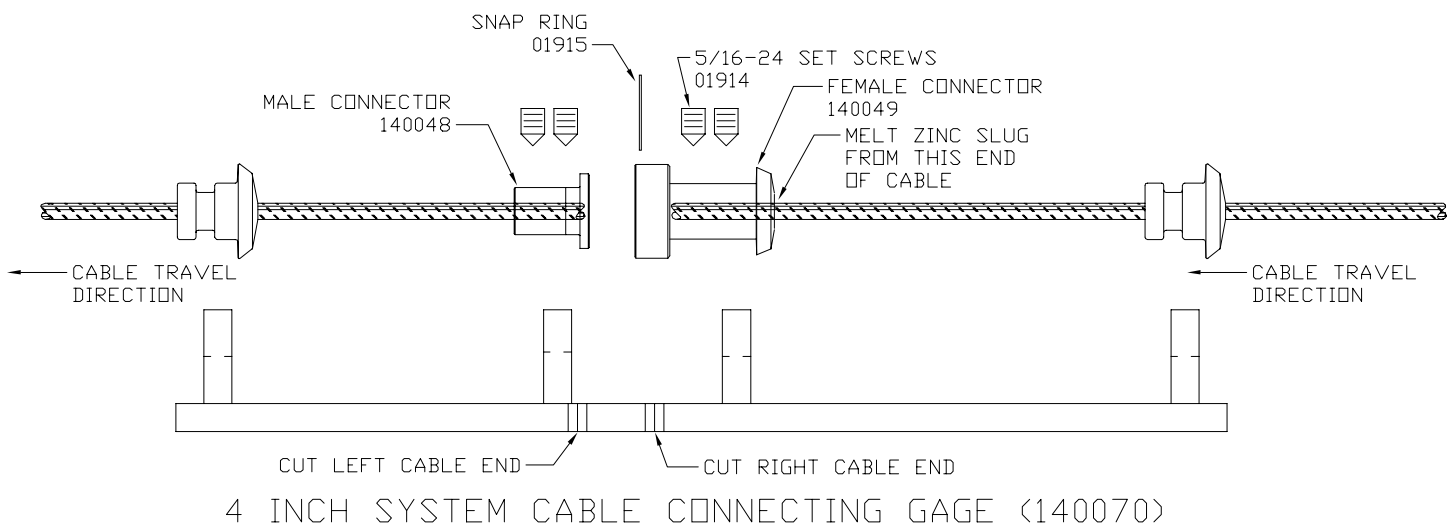

CABLE CONNECTOR

STAINLESS STEEL C00160SS



PART ASSEMBLY

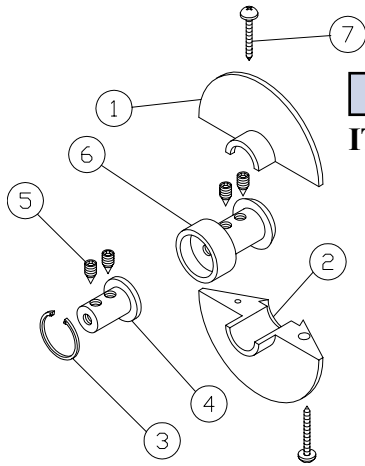

PART NUMBER IDENTIFICATION

C00160SS 4" STAINLESS STEEL CABLE CONNECTOR

ITEM	PART NO.	DESCRIPTION	QTY.
1	140051UHMW	4" BLACK CABLE CONNECTOR DISC	1
2	140051UHMW	4" WHITE CABLE CONNECTOR DISC	1
3	01915S	CONNECTOR SNAP RING, STAINLESS	1
4	140048S	CONNECTOR MALE, STAINLESS	1
5	01914S	5/16-24 CONNECTOR SET SCREW, STAINLESS	4
6	140049S	CONNECTOR FEMALE, STAINLESS	1
7	01984	#10 x 1 1/4 STAINLESS TAPPING SCREW	2

CABLE CONNECTOR KIT

C00159

FUNCTION

The **CABLE CONNECTOR KIT** has the tools needed to install a cable connector. Every system must have at least one connector to join the two ends of the cable.

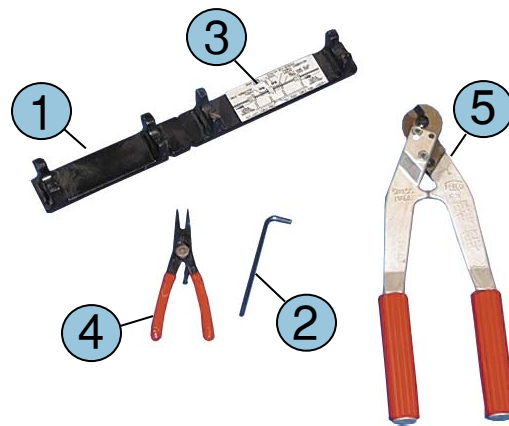

PART NUMBER IDENTIFICATION

ITEM	PART NO.	DESCRIPTION	QTY.
1	140070	4" CABLE CONNECTING GAUGE	1
2	01951	5/32 LONG ALLEN WRENCH	1
3	140070 1	4" CABLE CONNECTING GAUGE DECAL	1
4	01105	SNAP RING PLIERS	1
5	01950	4" CABLE CUTTER	1